

# The integration of discrete contourlet transform in OFDM framework for future wireless communication

Mohamed Hussien Mohamed Nerma<sup>1,2</sup>, Adam Mohamed Ahmed Abdo<sup>3</sup>

<sup>1</sup>Department of Computer Engineering, Faculty of Computers and Information Technology, University of Tabuk, Tabuk, Arab Saudi

<sup>2</sup>Department of Electronics Engineering College of Engineering, Sudan University of Sciences and Technology, Khartoum, Sudan

<sup>3</sup>Department of Electrical and Electronics Engineering, Faculty of Engineering Science, University of Nyala, Nyala, Sudan

## Article Info

### Article history:

Received Aug 30, 2024

Revised Oct 8, 2024

Accepted Nov 19, 2024

### Keywords:

BER

Contourlet transform

OFDM

PAPR

PSD

## ABSTRACT

In the upcoming era, the forthcoming sixth-generation (6G) wireless communication network will demand highly efficient technology to support extensive capacity, ultra-high speeds, low latency, scalability, and adaptability. While the current fifth-generation (5G) wireless communication system relies on OFDM technology, the evolution towards a beyond 5G wireless communication system necessitates a new OFDM framework. This study introduces a novel OFDM system that integrates the discrete Contourlet transform. A comparative analysis has been conducted among the proposed system, conventional OFDM, and curvelet-based OFDM systems. The results indicate that the proposed system offers improvements in bit error rate (BER), reduced computational complexity, decreased peak-to-average power ratio (PAPR), and enhanced power spectrum density (PSD) when contrasted with both the traditional and curvelet-based systems.

*This is an open access article under the [CC BY-SA](https://creativecommons.org/licenses/by-sa/4.0/) license.*

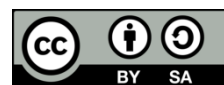

## Corresponding Author:

Mohamed Hussien Mohamed Nerma

Department of Computer Engineering, Faculty of Computers and Information Technology

University of Tabuk

Tabuk, Saudi Arabia

Email: mnerma@ut.edu.sa

## 1. INTRODUCTION

In 1957, the notion of transmitting a set of orthogonal subcarriers was introduced with the aim of efficiently sending these subcarriers without any overlap or disturbance [1], [2]. Initially, this idea was executed through the discrete fourier transform (DFT), which was suggested in 1971 [3]. Subsequently, the fast fourier transform (FFT) was utilized, leading to the emergence of the orthogonal frequency division multiplexing (OFDM) system as a promising field for exploration and analysis. Numerous publications have delved into subjects associated with this system [4]-[7].

As per references [1]-[4], OFDM represents a form of multicarrier modulation system (MCM) that employs an orthogonal multicarrier to concurrently transmit data devoid of any inter-carrier interference (ICI). While OFDM systems were integral to fifth-generation (5G) and earlier iterations, more sophisticated OFDM systems are imperative to meet the requisites of sixth-generation (6G) and forthcoming generations. The conventional OFDM system, grounded in the DFT, facilitates the successful transmission of multiple orthogonal data streams without overlapping symbols or inter-channel interference, thereby optimizing the data rate within the linear bandwidth [8]. The schematic for orthogonal parallel data transmission using DFT is depicted in Figure 1. Assuming  $x(n)$  signifies the discrete-time rendition of a time-domain signal,  $x(t)$ , the DFT transformation for  $x(n)$  in the frequency domain (FD), labeled as  $X(k)$ , can be articulated as:

$$X(k) = \sum_{n=0}^{N-1} x[n]e^{-j\frac{2\pi kn}{N}} \quad , \quad k = 0,1,2,\dots,N-1 \tag{1}$$

To obtain the inverse discrete-time domain signal (x(n)), which is the transformation of X(k) back into the discrete domain, the following equation can be utilized:

$$x(n) = \frac{1}{N} \sum_{k=0}^{N-1} X(k)e^{j\frac{2\pi kn}{N}} \quad , \quad n = 0,1,2,\dots,N-1 \tag{2}$$

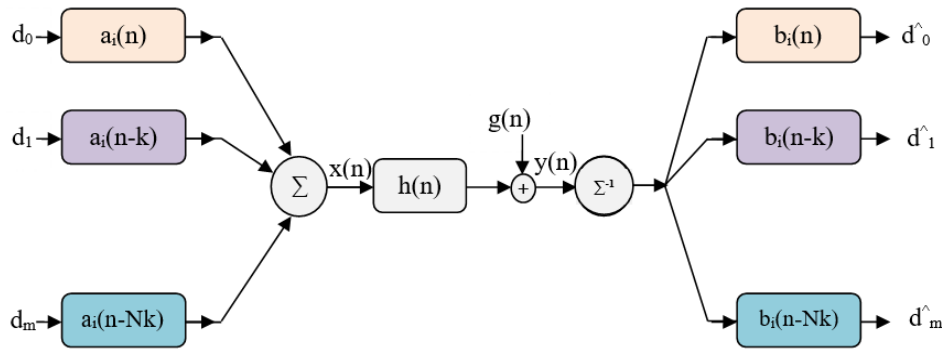

Figure 1. Block diagram of parallel and orthogonal data transmission

Considering a sequence of transmitted data as  $d_0, d_1, \dots, d_m$ , along with the discrete impulse response of the transmitter filter as  $a_i(n)$ . The transmission channel's discrete impulse response as  $h(n)$ , and the discrete channel's noise as  $g(n)$ , it can also be taking into account the receiver filter's discrete impulse response as  $b_i(n)$ , and a sequence of estimated received data as  $\hat{d}_0, \hat{d}_1, \dots, \hat{d}_m$ . Under these conditions, the expression for the transmitted signal can be derived using:

$$x(n) = \frac{1}{N} \sum_{k=0}^{N-1} a_k e^{j\frac{2\pi kn}{N}} \tag{3}$$

The signal that is ultimately received at the output can be described as:

$$y(n) = \frac{1}{N} \sum_{k=0}^{N-1} h(n, l)x(n-l) + g(n) \tag{4}$$

The signals received, denoted as  $y(n)$ , including  $y_1(n), y_2(n), \dots, y_m(n)$  are orthogonal, it implies that they are mutually perpendicular to one another.

$$\int_{-\infty}^{\infty} w_i(n)w_i(n-kT)dt = 0 \quad , \quad k = \pm 1, \pm 2, \dots \tag{5}$$

Where,  $w_i(n) = \int_{-\infty}^{\infty} d_i h(n-\tau)a_i(\tau)d\tau$ . In the discrete time domain, the correlation between  $d_i, a_i$  and  $h(n)$  will result in convolution, whereas in the discrete frequency domain, it will be represented by multiplication. If we assume flawless channel estimation and removal of noise, then the signal received can be expressed as:

$$Y_m = X_m H_m + g_m \tag{6}$$

Numerous alternative transformation methods have been suggested after the advent of the FFT. These encompass the modulated lapped transform (MLT), discrete cosine transform (DCT), discrete wavelet transform (DWT), wavelet packet transform (WPT), complex wavelet transform (CWT), complex wavelet packet transform (CWPT), dual-tree complex wavelet transform (DTCWT), and curvelets transform (CurT). Moreover, a novel transformation approach known as the discrete Contourlet transform (DConT) has been employed in this investigation.

The MCM systems are broadly divided into wired and wireless systems, as illustrated in Figure 2. Wireless systems employ block-transform methods for their execution, such as FFT, MLT, DCT, WT, and FDCurT. The WT-based systems can be further segmented into DWT, WPT, CWPT, and DTCWT.

Similarly, the CurT-based systems fall into two categories: FDCurT via USFFT and FDCurT via Wrapping. In this research, our attention is directed towards the DConT-based system as a transformative proposition in this work.

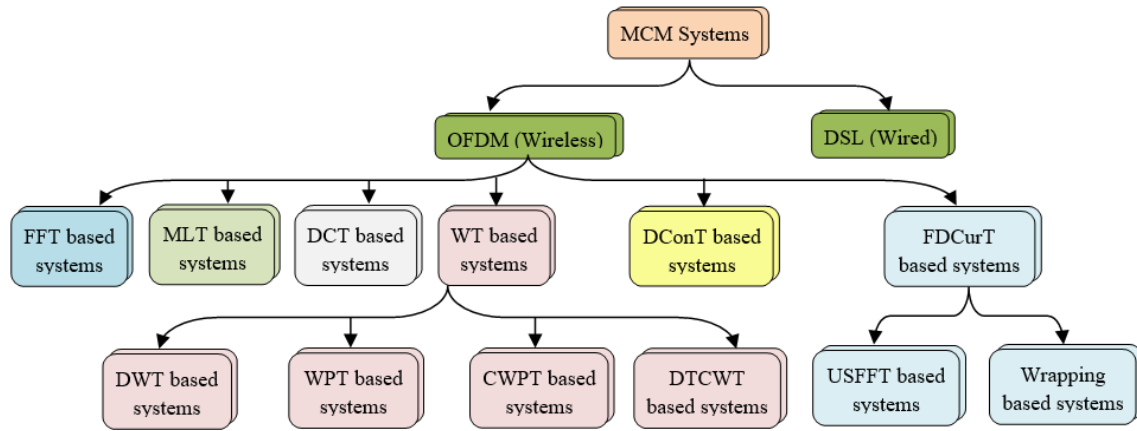

Figure 2. Classification of the MCM systems

**2. THE CONSIDERED SYSTEMS MODEL**

**2.1. The conventional system**

The OFDM system is based on the DFT, which involves both forward and inverse transformations [3]-[8]. In the transmitter, the inverse DFT (IDFT) is used, while the receiver utilizes the forward DFT. Assuming that there are N subcarriers, let  $d_N$  be the complex discrete transmitted data. The output of the IDFT results in the transmitted signal  $x(n)$ , which can be expressed as follows:

$$x(n) = \frac{1}{\sqrt{N}} \sum_{k=0}^{N-1} d_k e^{j\frac{2\pi n k}{N}}; \quad k = 0, 1, 2, \dots, N - 1 \tag{7}$$

Suppose that the channel impulse response is denoted as  $h(n)$  and the additive white Gaussian noise is represented by  $g(n)$ . On the receiving end, the signal received is referred to as  $y(n)$ .

$$y(n) = \frac{1}{\sqrt{N}} \sum_{k=0}^{N-1} d_k e^{j\frac{2\pi n k}{N}} * h(n) + g(n) \tag{8}$$

By utilizing the orthogonality characteristic, it is possible to detect the transmitted signal  $x(n)$  at the receiver end through DFT when considering perfect channel estimation. This can be achieved based on the information obtained from the received signal  $y(n)$ .

$$a_k = \sum_{n=0}^{N-1} y(n) e^{-j\frac{2\pi n k}{N}} \tag{9}$$

The retrieval of the complex set of transmitted data, in a discrete format ( $b_N$ ), is achievable through the implementation of the subsequent approach:

$$a_k = \sum_{k=0}^{N-1} \hat{a}_k \tag{10}$$

**2.2. MLT, DCT, and wavelet-based systems**

In OFDM systems utilizing MLT, the IFFT function was replaced with the inverse MLT (IMLT) function for transmission purposes. Conversely, the forward MLT function was used on the receiver side instead of the DFT function [9]-[11]. To denote this substitution,  $\beta^F[n]$  and  $\beta^I[n]$  were used as representations of the forward and inverse MLT functions, respectively. For the N subcarriers, if  $\varphi[n] = -\sin\left[\frac{(2n+1)\pi}{4N}\right]$  then:

$$\beta^F[n] = \phi[n] \sqrt{\frac{2}{N}} \cos \left[ \frac{\pi}{N} \left( \frac{2n+2k+N+2}{2} \right) \right] \quad (11)$$

If we denote the resulting signal at the output of the IMLT as  $x(n)$ , it can be expressed as follows:

$$x(n) = \sum_{k=0}^{N-1} d_k \beta^l[k] ; \quad k = 0,1,2, \dots, N-1 \quad (12)$$

In (13) and (14) represent the received signal  $y(n)$  and the output signal  $a_k$  attained through MLT on the receiving end, respectively.

$$y(n) = \sum_{k=0}^{N-1} d_k \beta^l[k] h(n) + g(n) \quad (13)$$

$$a_k = \sum_{k=0}^{N-1} y(n) \beta^l[k] \quad (14)$$

Research has shown that in order to utilize OFDM-based DCT, it is necessary to apply the forward DCT function (represented as  $\eta^F[n]$ ) on the transmitter side and the inverse DCT function (represented as  $\eta^l[n]$ ) on the receiver side [12]-[15]. This ensures optimal performance of the system while maintaining efficiency and accuracy.

$$\eta^l = \begin{cases} \sqrt{\frac{1}{N}} ; & k = 0 \\ \sqrt{\frac{2}{N}} \cos \left[ \pi n \left( \frac{2k+1}{2N} \right) \right] ; & k = 1,2,3, \dots, n-1 \end{cases} \quad (15)$$

After the transmission of the signal  $x(n)$ , the signal  $y(n)$  is received and then the data is estimated accordingly.

$$x(n) = \sum_{k=0}^{N-1} d_k \eta^l[k] ; \quad k = 0,1,2, \dots, N-1 \quad (16)$$

$$y(n) = \sum_{k=0}^{N-1} d_k \eta^l[k] * h(n) + g(n) \quad (17)$$

$$a_k = \sum_{k=0}^{N-1} y(n) \eta^F[k] \quad (18)$$

For the OFDM based on wavelet transform actually, various families of the wavelet transform were adopted in the OFDM system. Starting from the DWT [16]-[19], and then the WPT [20]-[23]. After that the CWPT [24]-[26], and finally the DT-CWT [27]-[36]. For the DWT, let  $\zeta(n)$  be the wavelet function, and  $l$  be the compression factor.  $x(n)$  at the output of the inverse DWT (IDWT) is:

$$x(n) = \sum_{l=0}^{\infty} \sum_{m=0}^{\infty} 2^{l/2} d_l^m \zeta(2^{l/2}n - m) \quad (19)$$

At the receiving end, the signal that has been received can be denoted as  $y(n)$  given in (20), whereas the signal that has been estimated at the output of DWT can be expressed as given in (21):

$$y(n) = x(n) * h(n) + g(n) \quad (20)$$

$$a_l^m = \hat{d}_l^m = \sum_{k=0}^{N-1} 2^{l/2} y(n) \zeta(2^{l/2}n - m) \quad (21)$$

In the context of DWPT, given the DWPT function  $\psi_k(n)$ , input data  $d_i$ , and input data constellation  $z_{i,j}$ , the resulting output signal  $x(n)$  obtained through the inverse DWPT (IDWPT) can be calculated as:

$$x(n) = \sum_i \sum_{j=0}^{M-1} z_{i,j} \psi_j(n - iM) \quad (22)$$

The signal that is received at the receiver side,  $y(n)$ , can be expressed in writing as:

$$y(n) = x(n) * h(n) + g(n) = \sum_k h(k) x(n - k) + g(n) \quad (23)$$

The estimation of the  $d_i$  can be achieved by taking the inner product ( $\langle \cdot, \cdot \rangle$ ) of functions, which is performed at the end of the process.

$$a_i = \langle x(n-k), \psi_i(n) \rangle \quad (24)$$

Incorporating the intricate iteration of wavelet transformation, the OFDM system utilized three distinct methods - the CWT, CWPT, and DTCWT. The transmission of signal  $x(n)$  was penned down utilizing the CWT and CWPT models.

$$x(n) = \sum_{m=i}^M \sum_{k=0}^{\infty} d_m(k) \gamma_{l,m}(n-kT) \quad (25)$$

The function  $\gamma_{l,m}(n)$  of either the CWT or the CWPT determines the received signal  $y(n)$ , represented in equation (20). Subsequently, the result yields an estimation of the data.

$$\hat{d}_i(n) = \sum_{m=i}^M \sum_{k=0}^{\infty} y(n) \gamma_{l,m}^*(n-kT) \quad (26)$$

Upon careful analysis, it has been discovered that the forward transform ( $Y$ ) for the DTCWT can be represented in the following manner:

$$Y = \begin{bmatrix} F_h \\ F_g \end{bmatrix} \quad (27)$$

The real and imaginary DTCWT are represented by  $F_h$  and  $F_g$  respectively. To obtain the inverse DTCWT (DTCWT), the following formula can be used:

$$Y^{-1} = \begin{bmatrix} F_h^{-1} & F_g^{-1} \end{bmatrix} \quad (28)$$

Subsequently, the signal  $x(n)$  that has been transmitted will appear at the output of the inverse Discrete Time Complex Wavelet Transform (IDT-CWT) in the following manner:

$$x(n) = Y^{-1} d_n \quad (29)$$

In (20) provides the value of the received signal,  $y(n)$ . Considering perfect channel estimation and noise elimination, the data estimated by DTCWT can be obtained from the output.

$$a_k = \sum_{k=0}^{N-1} Y * y(n) \quad (30)$$

### 2.3. The curvelet transform based system

Since the curvelets transform (CurT) was introduced [37]-[39], it proved that it's a very effective technique in different fields including image processing, seismic processing, turbulence analysis in fluid mechanics, solving of partial differential equations, compressed sensing or compressive sampling, and recently in the wireless communications [40]-[42].

Figure 3 illustrates the fast discrete curvelet transform (FDCurT) and its forward and reverse conversions utilizing wrapping based on the FFT. The forward conversion includes the conversion of data into the frequency domain through FFT. Subsequently, the data is multiplied by a sequence of window functions. The FFT coefficients are then 'wrapped' or folded into a rectangular form before being applied to the inverse FFT (IFFT). The curvelet coefficients are derived by executing the IFFT on the windowed data. The reverse transformation undoes the steps of the forward conversion process.

Assume that  $\varphi_\mu$  is the curvelet function then the curvelet coefficient ( $C_\mu$ ) can be obtained by the inner product between the signal  $x(t)$  and the curvelet function as:

$$C_\mu = \langle x(t), \varphi_\mu \rangle \quad (31)$$

The signal  $x(t)$  can be recovered back again by (32).

$$x(t) = \sum C_\mu \varphi_\mu(t) \quad (32)$$

For the OFDM based on CurT, the transmitted signal  $x(t)$  at the output of the inverse assume that the CurT (ICurT) is:

$$x(n) = \sum_{k,n=0}^{N-1} d_k \varphi_{\mu}(n) \tag{33}$$

The received signal  $y(n)$  is given as in (20). At the output of CurT, the estimated data under perfect channel estimation and noise elimination can be given by the inner product between the signal  $y(n)$  and the curvelet function as:

$$a_k = \langle y(n), \varphi_{\mu}(n) \rangle \tag{34}$$

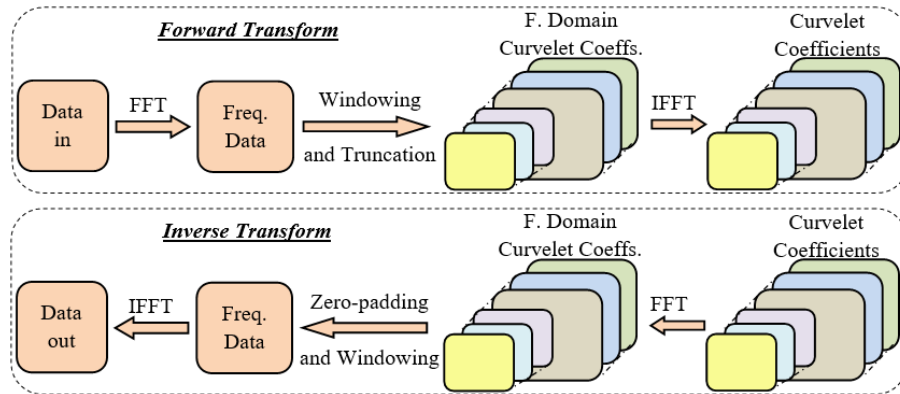

Figure 3. The forward and the inverse wrapping FDCurT

**2.4. The proposed system**

The drawbacks related to wavelet transform have been overcome by using the contourlet transform (ConT) [43]. The ConT [44] is a promising transformation that has been used in many fields including signal processing, seismic processing, and image processing [45]-[49]. To address the constraints of the wavelet transform, the ConT was introduced [43]-[44]. This innovative technique has been applied in diverse fields such as signal processing, seismic processing, and image processing [45]-[49]. Furthermore, in this study, it was utilized within wireless communications. The forward (decomposition) DConT is constructed by combining the Laplacian pyramid (LP) and the directional filter bank (DFB), as depicted in Figure 4. The output from the LP serves as the input to the DFB, resulting in a dual-iterated filter bank structure representing the discrete contourlet filter bank. Conversely, the inverse (reconstruction) DConT (IDConT) involves reversing the process of the forward DConT (FDConT), as illustrated in Figure 5 [44], [50].

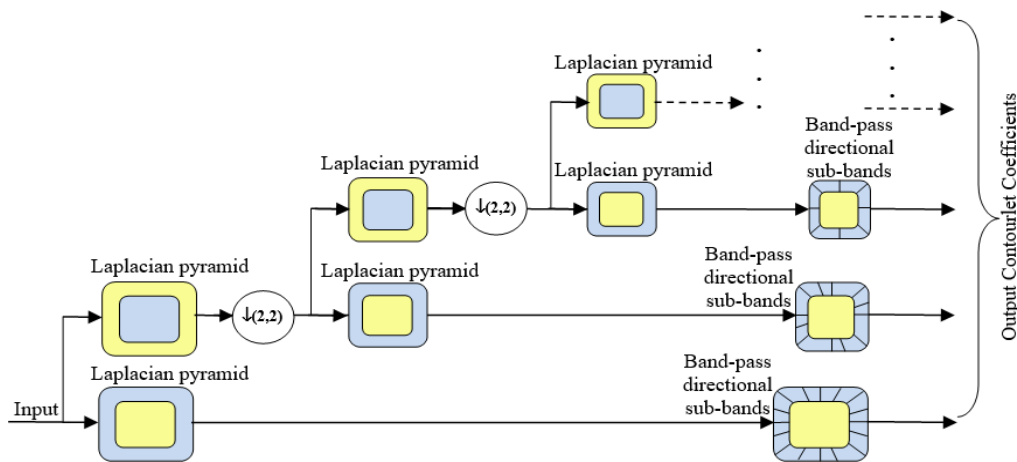

Figure 4. The Decomposition ConT

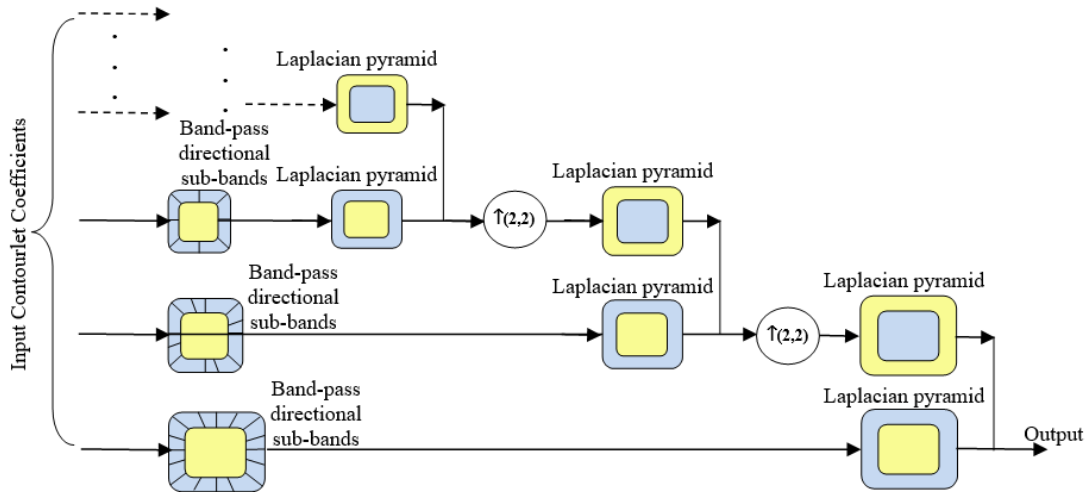

Figure 5. The reconstruction ConT

Figure 6 shows the DConT-based OFDM system. For the proposed system, the Inverse DConT (IDConT) is used on the transmitter side while the forward DConT (FDConT) is used on the receiver side. Assume that the ConT function is giving by:

$$\zeta_{r,p,\theta}(x) = \frac{1}{\sqrt{r}} \zeta \left[ \frac{a_1 \cos \theta + a_2 \sin \theta - p}{r} \right] \tag{35}$$

Moreover, the forward and the inverse ConT can be given respectively by:

$$\zeta(r, p, \theta) = \int \zeta_{r,p,\theta}(x) f(x) dx \tag{36}$$

$$f(x) = \int_0^{2\pi} \frac{\int_{-\infty}^{\infty} \int_0^{\infty} \zeta(r,p,\theta) \zeta_{r,p,\theta}(x) dr}{r^3} dp \frac{d\theta}{4\pi} \tag{37}$$

where  $r$  is the scaling factor,  $p$  is the translation factor, and  $\theta$  is the orientation factor. In the proposed system the discrete version of ConT has been used, and the integration in the continuous time ConT will be converted to summation in the discrete-time ConT. On the transmitter side, the IDConT is used, while the receiver side utilizes the FDConT.

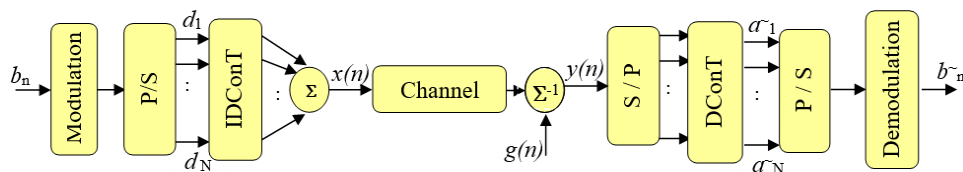

Figure 6. Block diagram of the OFDM based on the DConT

Assuming that there are  $N$  subcarriers, let  $d_N$  be the complex discrete transmitted data. The output of the inverse discrete ConT results in the transmitted signal  $x(n)$ , which can be expressed as follows:

$$x(n) = \sum_0^{2\pi} \sum_0^{\infty} \zeta_{r,p,\theta}(m) d_N(n) \tag{38}$$

At the receiver's end, the received signal  $y(n)$  will be as given in (20), the signal  $y'(n)$  at the output of the forward discrete ConT is:

$$y'(n) = \sum_0^{2\pi} \sum_0^\infty \zeta_{r,p,\theta}(m - kT) \zeta(r, p, \theta)y(n) \tag{39}$$

Figure 7 summarizes the set of transformations that were used in the OFDM system including the proposed ConT.

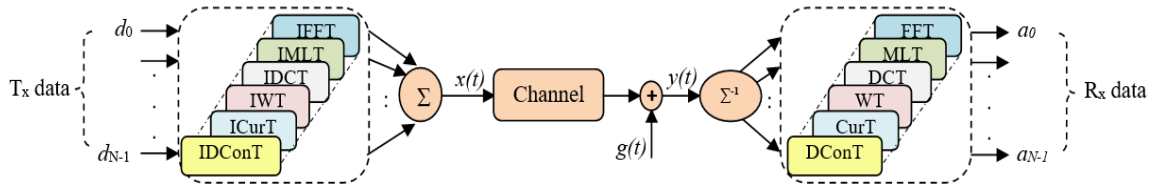

Figure 7. Block diagram of the OFDM based on numerous transformation methods

### 3. SIMULATION PROCEDURE

The flowchart depicted in Figure 8 outlines and encapsulates the simulation methodologies adopted in this study, with MATLAB® being the platform for implementation. The proposed system underwent a comparative analysis with both the conventional system reliant on the FFT-OFDM and the system based on the fast discrete curvelets transform utilizing the unequipped fast fourier transform (USFFT) (CurT-OFDM).

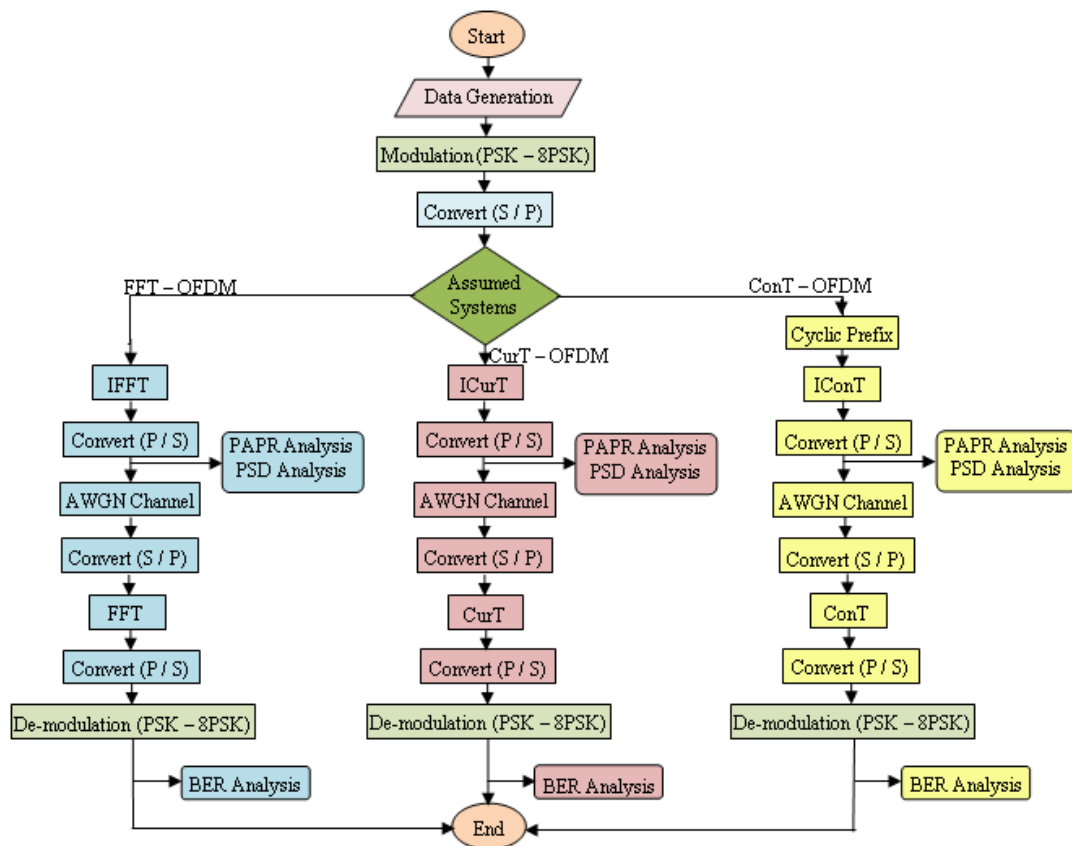

Figure 8. Simulation procedures flow chart

The performance evaluation of these three systems was conducted under the AWGN channel setting, focusing on aspects such as computational complexity, bit error rate (BER), and peak-to-average power ratio (PAPR). Utilizing 64 subcarriers and two modulation schemes (binary phase shift keying (PSK) and eight-phase shift keying (PSK)), the simulation parameters are succinctly outlined in Table 1.

Table 1. The simulation parameters

Parameters	Discription
Modulation type	BPSK, 8 PSK
Channel	AWGN channel
Cyclic prefix	1/4
Number of symbols	104 symbols
Number of subcarriers	64 subcarriers
PAPR threshold	2 dB
FFT OFDM system	Using the FFT
CurT OFDM system	Using the USFFT
ConT OFDM system	Using the pyramidal directional filter bank (PDFB)

#### 4. RESULTS AND DISCUSSION

To compare the proposed system with the conventional system based on the FFT and the OFDM system based on the CurT, the following considerations are taking into account: two types of modulation (BPSK and 8 PSK) have been used in this work under the AWGN channel using 64 and 256 subcarriers, with a 2 dB PAPR threshold, 104 symbols,  $\frac{1}{4}$  cyclic prefix, and 52 bit per OFDM symbol.

##### 4.1. The computational complexity

Computational complexity is an essential factor in the system's design, therefore in this work, this factor has been taken into account. Considering  $N$  is the number of subcarriers (subchannels), the traditional system i.e. OFDM based on the FFT and the OFDM based on the CurT have a computational complexity of order  $O(N \log N)$ . At the same time, the proposed OFDM system i.e. OFDM based on the ConT has a computational complexity of order  $O(N)$  [44]. The first blue curve represents the FFT-based OFDM system, the second black curve represents the CurT-based OFDM system, and the third red curve represents the ConT-based OFDM system. For  $N=256$  subcarriers, OFDM based on the FFT and the OFDM based on the CurT needs 1,420 operations while the OFDM based on the ConT needs only 256 operations for the same number of subcarriers. This means the OFDM based on the ConT achieved the lowest computational complexity as shown in Figure 9.

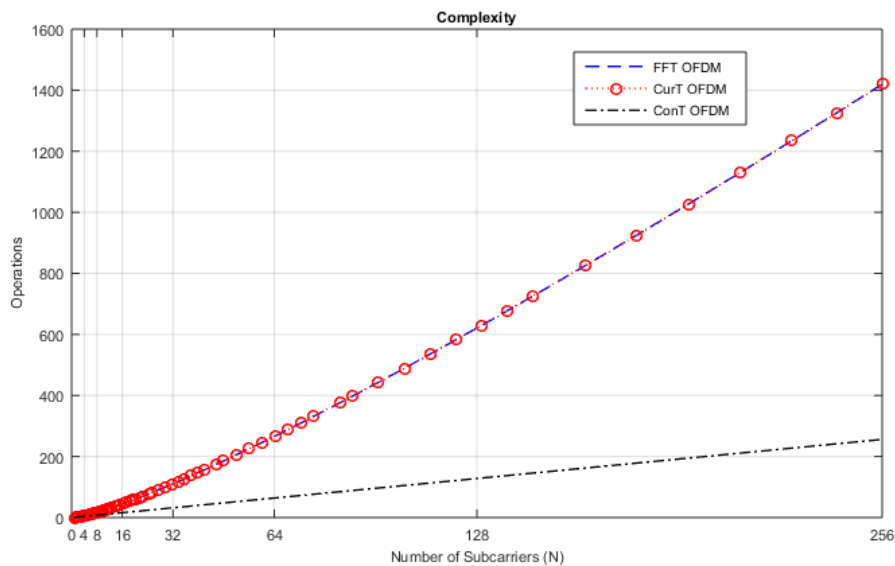

Figure 9. Computational complexity for the considered systems

##### 4.2. The bit error rate

The BER serves as a crucial metric for assessing system efficacy, indicating the likelihood of errors in transmitted data. Figure 10 illustrates the BER for the evaluated systems employing BPSK with 64 subcarriers, while Figure 11 displays the BER for the systems using 8 PSK with the same number of subcarriers. In these figures, the first blue curve corresponds to the FFT-based OFDM system, the second black curve represents the CurT-based OFDM system, and the third red curve depicts the ConT-based OFDM system. Observing Figures 10 and 11, it is evident that the OFDM system based on ConT demonstrates superior BER performance when compared to both the FFT-based system and the CurT-based system.

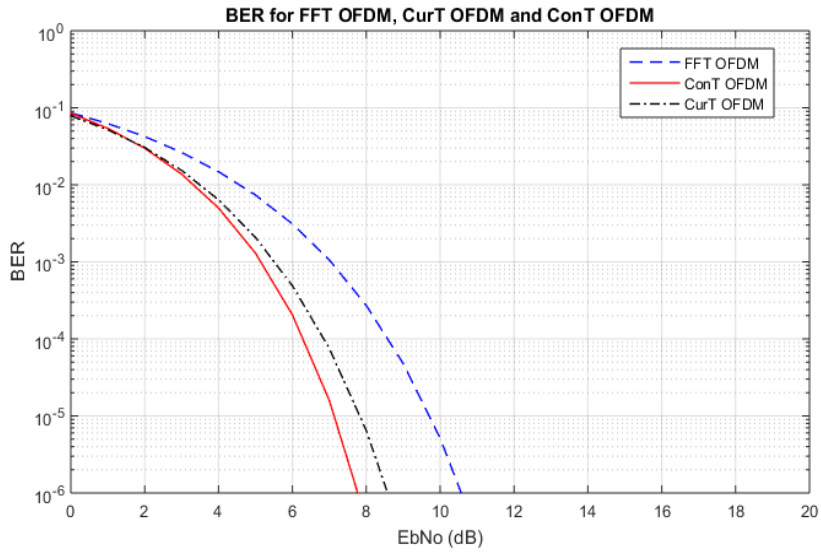

Figure 10. BER for the considered systems using BPSK

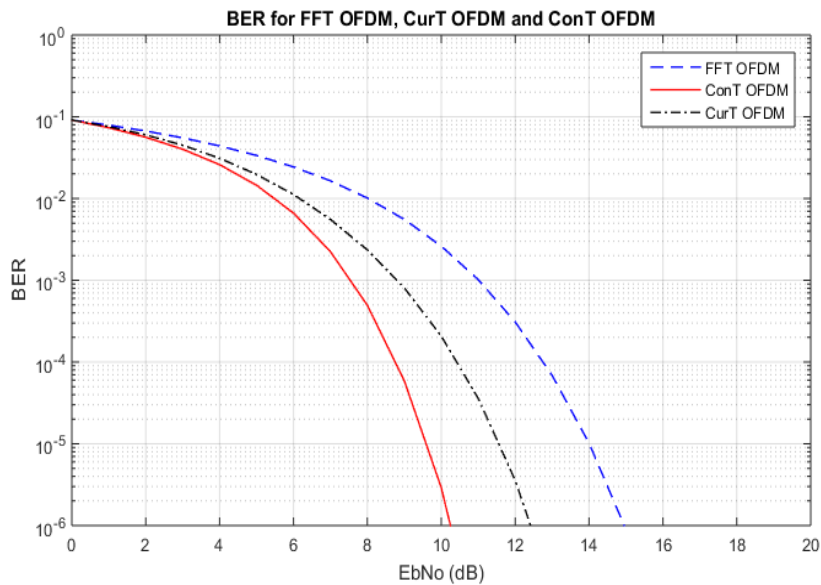

Figure 11. BER for the considered systems using 8 PSK

**4.3. The complementary cumulative distribution function**

This section showcases the complementary cumulative distribution function (CCDF) of the transmitted signal for the examined systems using 64 subcarriers, with the corresponding results presented in Figure 12. Figure 12 illustrates the CCDF for the systems employing BPSK with 64 subcarriers. Within this visualization, the first blue curve corresponds to the FFT-based OFDM system, the second black curve represents the CurT-based OFDM system, and the final red curve signifies the ConT-based OFDM system. Analysis of Figure 12 reveals that the OFDM system based on ConT yields superior PAPR outcomes when juxtaposed with both the FFT-based system and the CurT-based systems.

**4.4. The power spectrum density**

This section presents the power spectrum density (PSD) attributes. Figure 13 illustrates that the suppression of side lobes commenced at -37 dB, -32 dB, and -28 dB for the proposed system, the CurT-based system, and the FFT-based system, respectively. The proposed system demonstrates superior PSD outcomes compared to the FFT-based system and the ConT-based system in regard to enhanced out-of-band attenuation suppression.

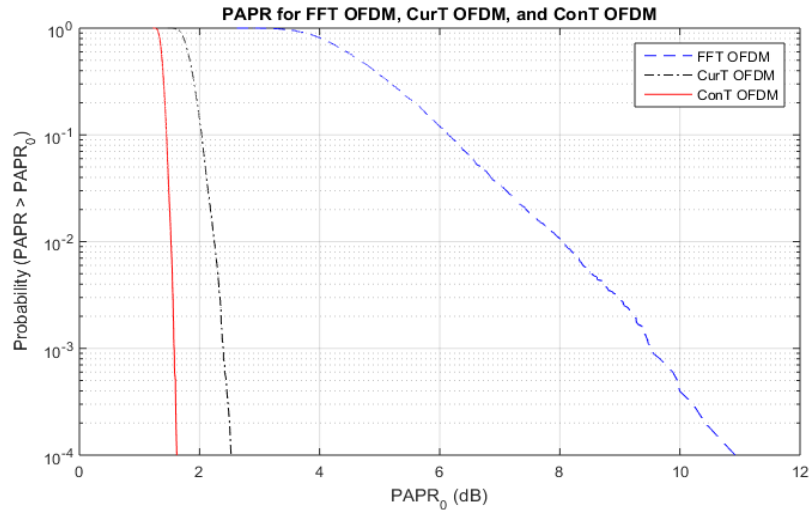

Figure 12. CCDF for the considered systems using 64 subcarriers

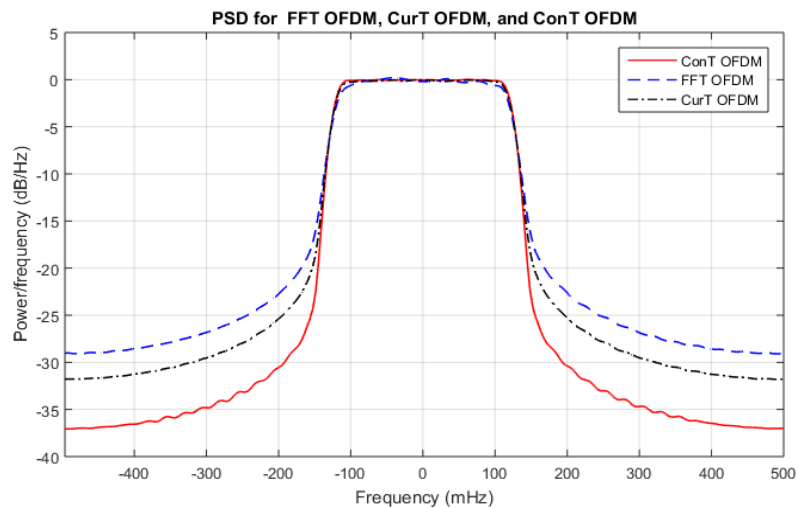

Figure 13. PSD for the considered systems using 64 subcarriers

## 5. CONCLUSION

In the forthcoming wireless communication system, an efficient implementation of OFDM technology is essential to fulfill its demands. This study introduces a novel OFDM system that relies on the DConT. The transmitter side of the proposed system employs IDConT, while the receiver side utilizes FConT. Three key performance metrics are compared across the conventional system, the curvelet-based system, and the proposed system. With 256 subcarriers, the traditional and curvelet-based systems required 1420 operations, whereas the proposed system only necessitated 256 operations. Additionally, concerning BER, the proposed system surpasses the other two systems. Results with 64 subcarriers indicate that the proposed OFDM system, based on the DConT, presents significant advantages in terms of PAPR compared to traditional FFT-based and CurT-based systems. Future research avenues encompass investigating channel estimation methods, synchronization techniques, PAPR mitigation strategies, and the integration of multiple antennas into the proposed system.

## REFERENCES





- [1] M. Doelz, E. Heald, and D. Martin, "Binary data transmission techniques for linear systems," *Proceedings of the IRE*, vol. 45, no. 5, pp. 656–661, 1957, doi: 10.1109/JRPROC.1957.278415.
- [2] R. R. Mosier and R. G. Clabaugh, "Kineplex, a bandwidth-efficient binary transmission system," *Transactions of the American Institute of Electrical Engineers, Part I: Communication and Electronics*, vol. 76, no. 6, pp. 723–728, Jan. 1958, doi: 10.1109/TCE.1958.6372736.

- [3] S. Weinstein and P. Ebert, "Data Transmission by frequency-division multiplexing using the discrete fourier transform," *IEEE Transactions on Communication Technology*, vol. 19, no. 5, pp. 628–634, Oct. 1971, doi: 10.1109/TCOM.1971.1090705.
- [4] R. van Nee and R. And Prasad, *OFDM for wireless multimedia communications*. Artech House Artech House, 2000.
- [5] R. Prasad, *OFDM for wireless communications systems*. Artech House Universal Personal Communications Library/Artech House, 2004.
- [6] A. R. S. Bahai, B. R. Saltzberg, and M. Ergen, *Multi-carrier digital communications theory and applications of OFDM*. Springer Science & Business Media, 2004.
- [7] L. Hanzo and T. Keller, *OFDM and MC-CDMA*. John Wiley & Sons, 2006.
- [8] R. W. Chang, "Synthesis of band-limited orthogonal signals for multichannel data transmission," *Bell System Technical Journal*, vol. 45, no. 10, pp. 1775–1796, Dec. 1966, doi: 10.1002/j.1538-7305.1966.tb02435.x.
- [9] X. Chen and Q. Dai, "A novel DCT-based algorithm for computing the modulated complex lapped transform," *IEEE Transactions on Signal Processing*, vol. 54, no. 11, pp. 4480–4484, Nov. 2006, doi: 10.1109/TSP.2006.881191.
- [10] G. J. Saulnier, M. Mettke, and M. J. Medley, "Performance of an OFDM spread spectrum communications system using lapped transforms," in *MILCOM 97 MILCOM 97 Proceedings*, 1997, vol. 2, pp. 608–612, doi: 10.1109/MILCOM.1997.646693.
- [11] G. J. Saulnier, V. A. Alanzo Whyte, and M. J. Medley, "An OFDM spread spectrum system using lapped transforms and partial band interference suppression," in *1996 IEEE Digital Signal Processing Workshop Proceedings*, 1996, pp. 121–124, doi: 10.1109/DSPWS.1996.555475.
- [12] Z. Sufyanu, F. S. Mohamad, A. A. Yusuf, and M. B. Mamat, "Enhanced face recognition using discrete cosine transform," *Engineering Letters*, vol. 24, no. 1, pp. 52–61, 2016.
- [13] G. D. Mandyam, "On the discrete cosine transform and OFDM systems," in *2003 IEEE International Conference on Acoustics, Speech, and Signal Processing, 2003. Proceedings. (ICASSP '03).*, 2003, vol. 4, pp. IV-544–7, doi: 10.1109/ICASSP.2003.1202700.
- [14] B. Lee, "A new algorithm to compute the discrete cosine transform," *IEEE Transactions on Acoustics, Speech, and Signal Processing*, vol. 32, no. 6, pp. 1243–1245, Dec. 1984, doi: 10.1109/TASSP.1984.1164443.
- [15] C. W. Kok, "Fast algorithm for computing discrete cosine transform," *IEEE Transactions on Signal Processing*, vol. 45, no. 3, pp. 757–760, Mar. 1997, doi: 10.1109/78.558495.
- [16] M. A. Tzannes, M. C. Tzannes, J. Proakis, and P. N. Heller, "DMT systems, DWMT systems and digital filter banks," in *Proceedings of ICC/SUPERCOMM'94 - 1994 International Conference on Communications*, 1994, pp. 311–315, doi: 10.1109/ICC.1994.369039.
- [17] A. N. Akansu and Xueming Lin, "A comparative performance evaluation of DMT (OFDM) and DWMT (DSBMT) based DSL communications systems for single and multitone interference," in *Proceedings of the 1998 IEEE International Conference on Acoustics, Speech and Signal Processing, ICASSP '98 (Cat. No.98CH36181)*, 1998, vol. 6, pp. 3269–3272, doi: 10.1109/ICASSP.1998.679562.
- [18] M. C. Sun and D. P. K. Lun, "Power-line communications using DWMT modulation," in *2002 IEEE International Symposium on Circuits and Systems. Proceedings (Cat. No.02CH37353)*, 2002, vol. 4, pp. IV-493-IV-496, doi: 10.1109/ISCAS.2002.1010500.
- [19] J. Ou, B. Zhou, X. Zhang, and X. Liao, "Performance Improvement of multi-level redundant discrete wavelet transform OFDM system by using LDPC encoding and belief propagation algorithm," in *2023 8th International Conference on Computer and Communication Systems (ICCCS)*, Apr. 2023, pp. 269–273, doi: 10.1109/ICCCS57501.2023.10151120.
- [20] A. R. Lindsey, "Wavelet packet modulation for orthogonally multiplexed communication," *IEEE Transactions on Signal Processing*, vol. 45, no. 5, pp. 1336–1339, May 1997, doi: 10.1109/78.575704.
- [21] D. Daly, C. Heneghan, A. Fagan, and M. Vetterli, "Optimal wavelet packet modulation under finite complexity constraint," in *IEEE International Conference on Acoustics Speech and Signal Processing*, May 2002, pp. III-2789-III-2792, doi: 10.1109/ICASSP.2002.5745227.
- [22] A. Jamin and P. Mähönen, "Wavelet packet modulation for wireless communications," *Wireless Communications and Mobile Computing*, vol. 5, no. 2, pp. 123–137, Mar. 2005, doi: 10.1002/wcm.201.
- [23] T. S. V. Vardhan D, N. Kumar A, V. Kumar P, C. Kiran K, J. G, and R. Raja A, "Fusion of adaptive SLM technique with companding for PAPR reduction in 5G MIMO-OFDM System," in *2023 Second International Conference on Electrical, Electronics, Information and Communication Technologies (ICEEICT)*, Apr. 2023, pp. 1–5, doi: 10.1109/ICEEICT56924.2023.10157778.
- [24] K. M. Wong, J. Wu, T. N. Davidson, Q. Jin, and P.-C. Ching, "Performance of wavelet packet-division multiplexing in impulsive and Gaussian noise," *IEEE Transactions on Communications*, vol. 48, no. 7, pp. 1083–1086, Jul. 2000, doi: 10.1109/26.855513.
- [25] R. Duala and P. T. Rao "A comprehensive analysis of dynamic PAPR reduction schemes in MIMO-OFDM systems" *International Journal of Informatics and Communication Technology*, Vol. 13, No. 2, pp. 248 - 256, 2024, doi: 10.11591/ijict.v13i2.pp248-256.
- [26] M. You and J. Ilow, "A multi-wavelet packet modulation in wireless communications," in *Canadian Conference on Electrical and Computer Engineering 2004 (IEEE Cat. No.04CH37513)*, 2004, pp. 2367–2370, doi: 10.1109/CCECE.2004.1347722.
- [27] M. Gömeç *et al.*, "Dual Tree Complex Wavelet Transform Based Multi Carrier Communication Systems," *2019 42nd International Conference on Telecommunications and Signal Processing (TSP)*, Budapest, Hungary, 2019, pp. 651–654, doi: 10.1109/TSP.2019.8768852.
- [28] M. H. M. Nerma, N. S. Kamel, and V. J. Jagadish, "On DT-CWT based OFDM: PAPR analysis," in *Multi-Carrier Systems & Solutions 2009. Lecture Notes in Electrical Engineering*, vol. 41 LNEE, Springer, Dordrecht, 2009, pp. 207–217.
- [29] M. H. Nerma, N. Kamel, and V. Jeoti, "An OFDM system based on dual tree complex wavelet transform ( DT-CWT )," *Signal Processing: An International Journal*, vol. 3, no. 2, pp. 14–26, 2009.
- [30] M. H. M. Nerma, N. S. Kamel, and V. Jeoti, "Performance analysis of a novel OFDM system based on dual – tree complex wavelet transform ( DT-CWT )," *UbiCC Journal*, vol. 4, no. 3, pp. 813–822, 2009.
- [31] M. H. M. Nerma, N. S. Kamel, and V. J. Jagadish, "Investigation of using dual tree complex wavelet transform (DT-CWT) to improve the performance of OFDM system," *Engineering Letters*, vol. 20, no. 2, p. 3, 2012.
- [32] M. H. M. Nerma, N. S. Kamel, and V. Jeoti, "BER performance analysis of OFDM system based on dual – tree complex wavelet transform in AWGN channel," in *Proceedings of the 8th WSEAS International Conference on Signal Processing*, 2009, pp. 85–89.
- [33] M. H. M. Nerma, V. Jeoti, and N. S. Kamel, "The effects of HPA on OFDM system based on dual - tree complex wavelet transform (DTCWT)," in *2010 International Conference on Intelligent and Advanced Systems*, Jun. 2010, pp. 1–4, doi: 10.1109/ICIAS.2010.5716173.
- [34] M. H. M. Nerma, V. J. Jagadish, and N. N. S. Kamel, "The effects of shift-invariance property in DTCWT-OFDM system," in *2012 International Conference on Innovations in Information Technology (IIT)*, Mar. 2012, pp. 17–21, doi: 10.1109/INNOVATIONS.2012.6207727.





- [35] A. Sindgi and U. B. Mahadevaswamy, "Wavelet-Powered mm-Wave OFDM for Efficient Wireless Network-on-Chip Communication," *2023 International Conference on Network, Multimedia and Information Technology (NMITCON)*, Bengaluru, India, 2023, pp. 1-8, doi: 10.1109/NMITCON58196.2023.10275891.
- [36] E. Candes, D. L. Donoho, E. J. Candès, and D. L. Donoho, "Curvelets: a surprisingly effective nonadaptive representation of objects with edges," in *Proceedings of the International Conference on Curves and Surfaces*, 1999, pp. 105–120.
- [37] A. Gulbaz, E. K. Caliskan, B. Tengizler, and A. Ozen, "A new fast discrete curvelet transform spread OFDM waveform based on FWHT," in *2022 30th Signal Processing and Communications Applications Conference (SIU)*, May 2022, pp. 1–4, doi: 10.1109/SIU55565.2022.9864709.
- [38] E. Candès, L. Demanet, D. Donoho, and L. Ying, "Fast discrete curvelet transforms," *Multiscale Modeling and Simulation*, vol. 5, no. 3, pp. 861–899, 2006, doi: 10.1137/05064182X.
- [39] M. H. M. Nerma and M. A. A. Elmaleeh, "PAPR for OFDM system based on fast discrete curvelet transform," *Journal of Engineering Science and Technology*, vol. 13, no. 9, pp. 2805–2819, 2018.
- [40] M. H. M. Nerma, "Utilization of the fast discrete curvelet transform in the OFDM system," *International Journal of Digital Information and Wireless Communications*, vol. 10, no. 2, pp. 21–28, 2020, doi: 10.17781/P002656.
- [41] M. H. M. Nerma, "A review of the transformation techniques in the of DM system," *Journal of Engineering Science and Technology*, vol. 16, no. 1, pp. 176–193, 2021.
- [42] M. N. Do, "Directional multiresolution image representations," Bachelor of Engineering in Computer Engineering, University of Canberra, 2002.
- [43] M. N. Do and M. Vetterli, "The contourlet transform: an efficient directional multiresolution image representation," *IEEE Transactions on Image Processing*, vol. 14, no. 12, pp. 2091–2106, Dec. 2005, doi: 10.1109/TIP.2005.859376.
- [44] S. Kollem, K. R. Reddy, and D. S. Rao, "Improved partial differential equation-based total variation approach to non-subsampled contourlet transform for medical image denoising," *Multimedia Tools and Applications*, vol. 80, no. 2, pp. 2663–2689, Jan. 2021, doi: 10.1007/s11042-020-09745-1.
- [45] G. H. Toro Garay and R. J. Medina Daza, "Fusion of WorldView2 images using Contourlet, curvelet and ridgelet transforms for edge enhancement," *Revista Facultad de Ingeniería Universidad de Antioquia*, no. 85, pp. 8–17, Dec. 2017, doi: 10.17533/udea.redin.n85a02.
- [46] P. Birajadar and A. Shete, "A comparative performance analysis of CBIR using wavelet and contourlet transform," in *2023 Fifth International Conference on Electrical, Computer and Communication Technologies (ICECCT)*, Feb. 2023, pp. 1–5, doi: 10.1109/ICECCT56650.2023.10179614.
- [47] V. M. Kamble, P. Parlewar, A. G. Keskar, and K. M. Bhurchandi, "Performance evaluation of wavelet, ridgelet, curvelet and contourlet transforms based techniques for digital image denoising," *Artificial Intelligence Review*, vol. 45, no. 4, pp. 509–533, Apr. 2016, doi: 10.1007/s10462-015-9453-7.
- [48] S. Jayashree, M. V Karki, K. Indira, and N. Shivashankarappa, "Performance analysis of image fusion rules implemented on nonsubsampling contourlet transform decomposed images for pansharpening," in *2022 4th International Conference on Circuits, Control, Communication and Computing (I4C)*, Dec. 2022, pp. 103–108, doi: 10.1109/I4C57141.2022.10057727.
- [49] E. Hatami, H. Rashidy Kanan, K. Layeghi, and A. Harounabadi, "An optimized robust and invisible digital image watermarking scheme in Contourlet domain for protecting rightful ownership," *Multimedia Tools and Applications*, vol. 82, no. 2, pp. 2021–2051, Jan. 2023, doi: 10.1007/s11042-022-13197-0.
- [50] F. Yasmeen and M. S. Uddin, "An efficient image steganography approach based on QR factorization and singular value decomposition in non-subsampled contourlet transform domain," *Security and Privacy*, vol. 5, no. 4, p. e229, Jul. 2022, doi: 10.1002/spy2.229.

## BIOGRAPHIES OF AUTHORS



**Mohamed Hussien Mohamed Nerma**     received his Ph.D. from the Universiti Teknologi PETRONAS, Malaysia in Electrical and Electronic Engineering in 2010. His research is focused on wireless communication system design, wireless multimedia communication networks, PHY layer issues of MIMO and OFDM technologies, cognitive radio, optical fiber communications telecommunication and signal processing, wavelet, curvelet, and contourlet for applications in the wireless communication area. Currently, he is working as an Associate Professor in the Department of Computers and Information Technology, University of Tabuk, Kingdom of Saudi Arabia, Tabuk. He is a senior member of IEEE. He can be contacted at email: eng\_kassala@hotmail.com.



**Adam Mohamed Ahmed Abdo**     received his Bachelor's and Master's degrees in Communication Engineering at the School of Electronic Engineering, Sudan University of Science and Technology in 2007 and 2014 respectively. Furthermore, he received his Ph.D. Degree from north China electric power university, Beijing, China in June 2019. From January 2014 to September 2015, he was a Senior Lecturer at the Faculty of Engineering Science, Electrical and Electronic Department, University of Nyala, Nyala, Sudan. Presently, he is working as an assistant professor at the Department of Electrical and Electronic Engineering, Faculty of Engineering Science, University of Nyala. His main field of interest is wireless mobile communication technologies, 5G in millimeter wave communications, and beamforming and signal processing. He can be contacted at email: oadam\_ma83@yahoo.com.